

HOME DESIGN TRENDS

45°

INFLUENCED BY OLDER ADULTS

EASY-ACCESS KITCHENS

Universal kitchens reduce the need to bend or reach.

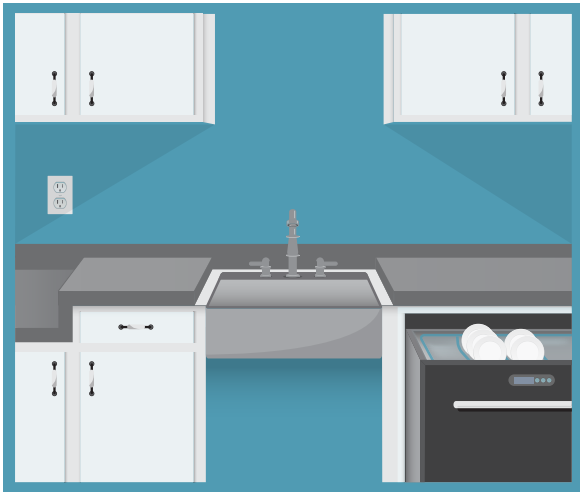

Top Features:

- Larger, easy-to-grab pulls instead of knobs
- Ranges with controls at the front
- Varied counter heights
- Lever-handle faucets
- Drawer-style appliances, such as dishwashers



Recommended amount of floor space in front of appliances, for universal accessibility

WIDE-OPEN SPACES

Open-space floor plans have fewer hallways and doorways, making it easier to move around.

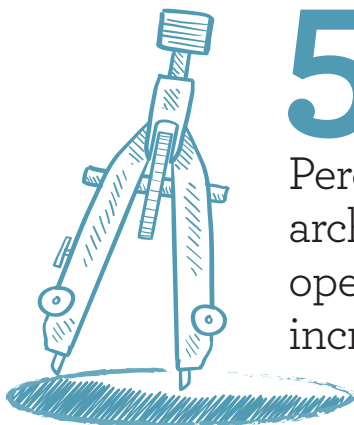

53%

Percentage of residential architects who say open-space layouts are increasing in popularity

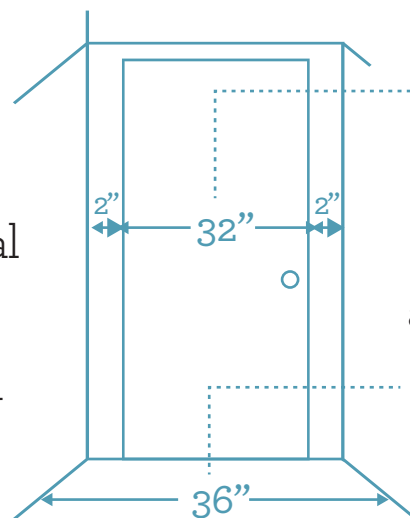

Minimum amount of clear width through doorways for accessible homes

Minimum width of hallways

IMPROVED LIGHTING

Well-lit rooms and halls can help prevent falls.



44"–48"



Recommended height for light switches so they're easy to reach from a seated position

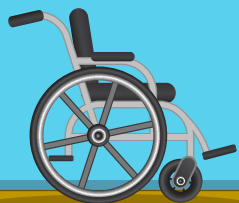

Easy upgrades:

\$14–\$75+

Cost of remote controls for lights

\$25–\$140

Cost of motion-controlled light switches

FIRST-FLOOR MASTER SUITES

First-floor bedrooms reduce mobility challenges for seniors and people with disabilities.



Among households with a member age 85 or older, **35%** of people 65 and up have a disability.



88%

of seniors want one-level living.

SAFER BATHROOMS

Bathrooms offer the most accessibility add-ons.

Top Features:

- Grab bars
- Handheld showerheads
- Benches or fold-down shower seats
- Off-center, easy-to-reach shower controls
- Non-slip flooring
- Roll-in or curbless showers

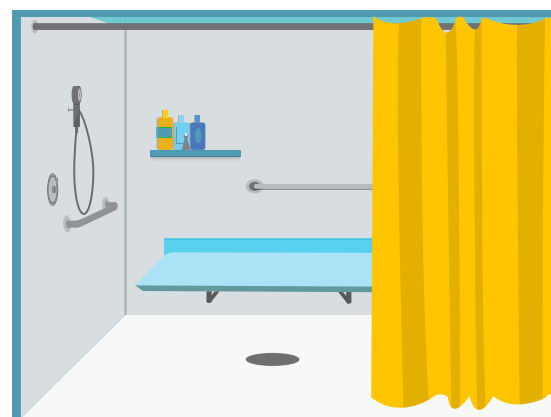

HOME DESIGN TRENDS

45°

INFLUENCED BY OLDER ADULTS

EASY-ACCESS KITCHENS

Universal kitchens reduce the need to bend or reach.



Top Features:

- Larger, easy-to-grab pulls instead of knobs
- Ranges with controls at the front
- Varied counter heights
- Lever-handle faucets
- Drawer-style appliances, such as dishwashers

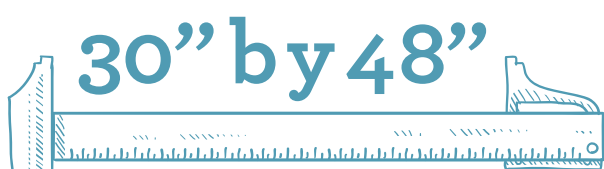

Recommended amount of floor space in front of appliances, for universal accessibility

WIDE-OPEN SPACES

Open-space floor plans have fewer hallways and doorways, making it easier to move around.

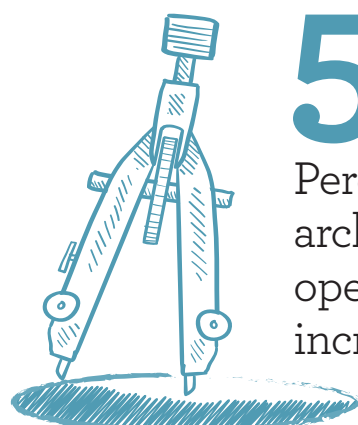

53%

Percentage of residential architects who say open-space layouts are increasing in popularity

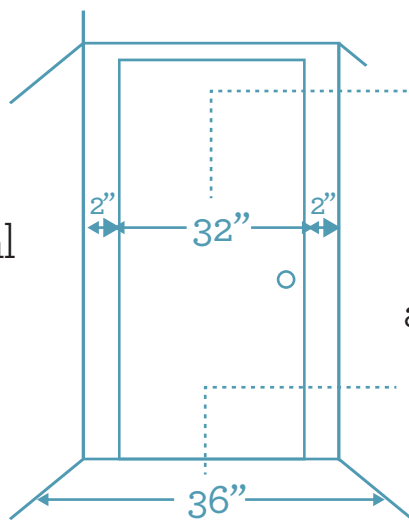

Minimum amount of clear width through doorways for accessible homes
Minimum width of hallways

IMPROVED LIGHTING

Well-lit rooms and halls can help prevent falls.



44"–48"
Recommended height for light switches so they're easy to reach from a seated position

Easy upgrades:

- \$14–\$75+**
Cost of remote controls for lights
- \$25–\$140**
Cost of motion-controlled light switches



FIRST-FLOOR MASTER SUITES

First-floor bedrooms reduce mobility challenges for seniors and people with disabilities.



Among households with a member age 85 or older, **35%** of people 65 and up have a disability.



88%

 of seniors want one-level living.

SAFER BATHROOMS

Bathrooms offer the most accessibility add-ons.

Top Features:

- Grab bars
- Handheld showerheads
- Benches or fold-down shower seats
- Off-center, easy-to-reach shower controls
- Non-slip flooring
- Roll-in or curbless showers

